

KAHL Flat Die Pelleting Presses

Type survey

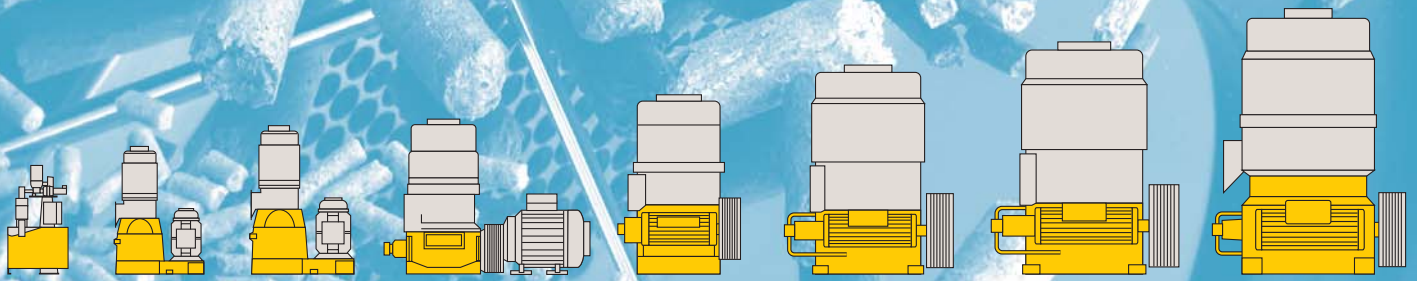

Flat Die Pelleting Presses for various applications

14-175

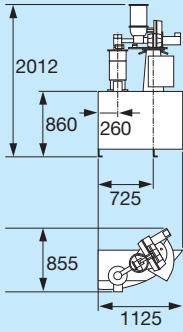

Pelleting presses for producing small quantities

Type	14-175
Die diameter mm	175
Roller diameter/width mm	130/29
Number of rollers	2
Drive motor kW/min ⁻¹	3
Roller speed m/s	0.5-0.8
Perforated die area cm ²	106
Machine weight kg with motor	260

Pelleting presses for processing pas

Type	
Die diameter mm	
Roller diameter/width mm	
Number of rollers	
Drive motor kW/min ⁻¹	
Roller speed m/s	
Perforated die area cm ²	
Machine weight kg with motor	

Pelleting presses for producing medium and large quantities

Type	33-390	33-500	34-600	38-600	38-780
Die diameter mm	390	500	600	600	780
Roller diameter/width mm	230/77	230/77	280/102	280/102	280/102
Number of rollers	2	3	3-4	3-4	3-4
Drive motor kW/min ⁻¹	15-30/1500*	15-30/1500	45-55/750	55-75/1500*	55-75/1500*
Roller speed m/s	2.2	2.4	2.7	2.6	2.6
Perforated die area cm ²	617	840	1382	1382	1382
Machine weight kg with motor	1150	1300	2330	2250	2250

The dimensions indicated refer to the biggest drive motor available.
Please see page 4 for possible installation and dimensions of feeding units.

33-390

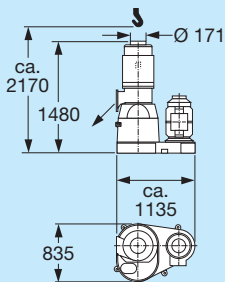

33-500

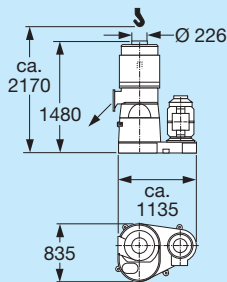

34-600

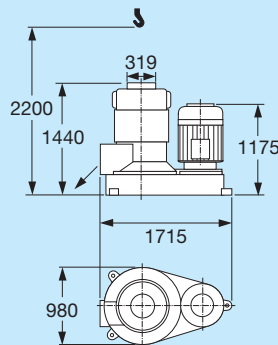

38-600

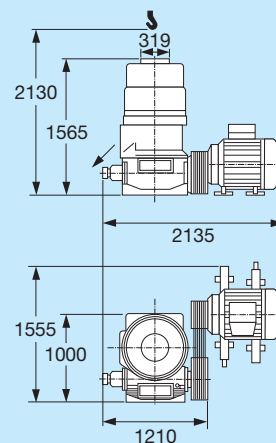

38-780

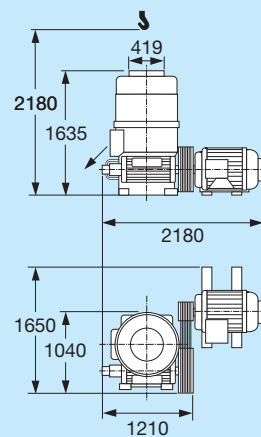

sty materials

24-390	25-500
390	500
230/77	230/77
2	3
30	30
1.65	1.72
617	840
1800	1950

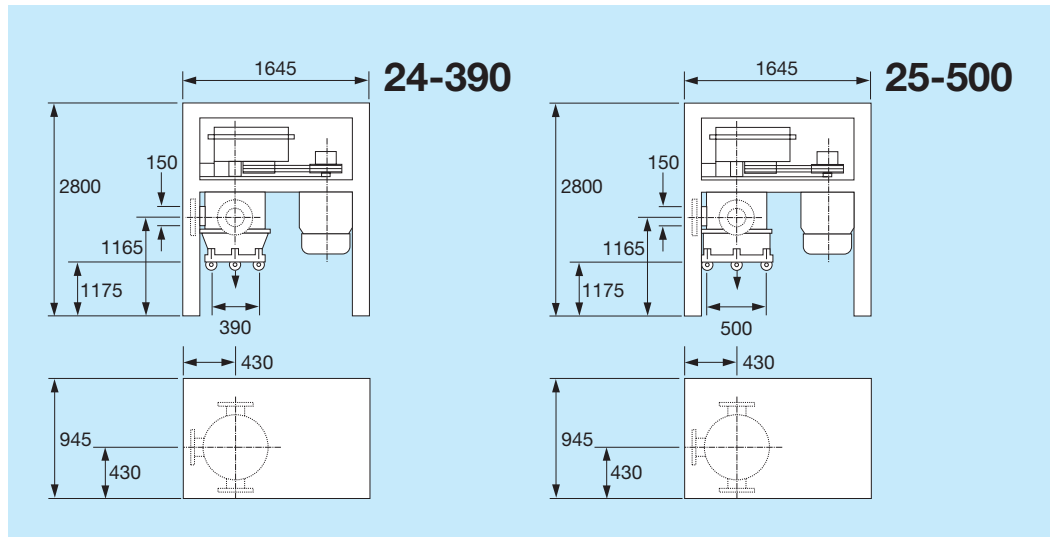

38-780	37-850	39-1000	45-1250	60-1250
780	850	1000	1250	1250
350/102 or 350/102	350/132	350/156 or 450/156	450/192 or 450/156	450/192
3-5 or 3-4	3-5	3-5 or 3-4	4-5	4-5
90-110/1500*	132/1500*	160-200/1500*	200-250/1500*	2 x 160-200/1500*
2.6	2.5	2.6	2.7	2.6
1916	2695	3850	5900	5900
3000	4600	5400	9000	9370

*other speeds possible

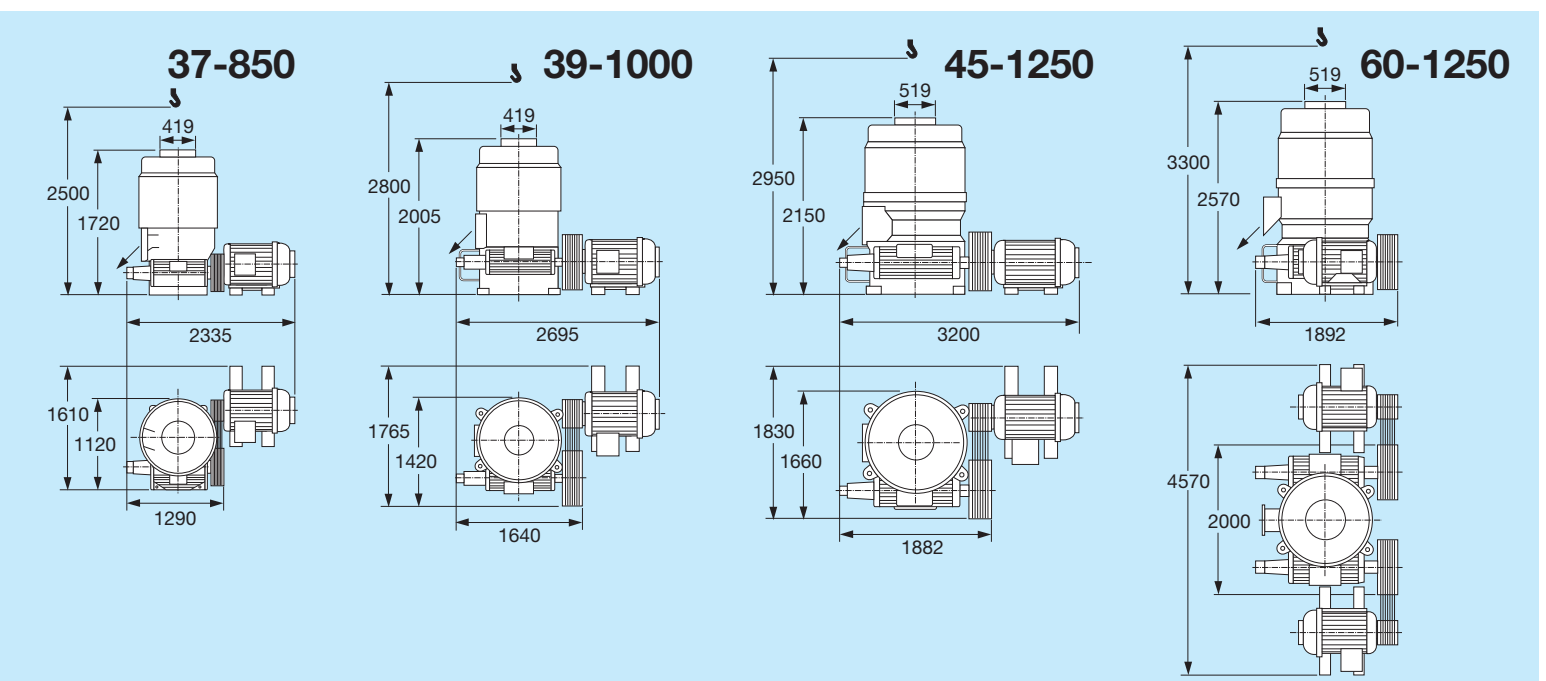

Additional technical data

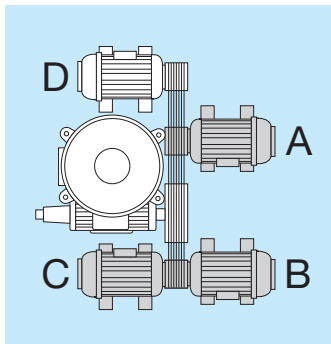

Motors with V-belt drives can be mounted in different positions

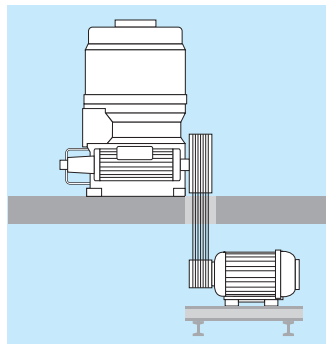

The press motor can be mounted below the ceiling.

Feeding equipment

Proportioning screw D

Size	160	250	315
A mm	1050	1800	1800
B mm	412	502	597

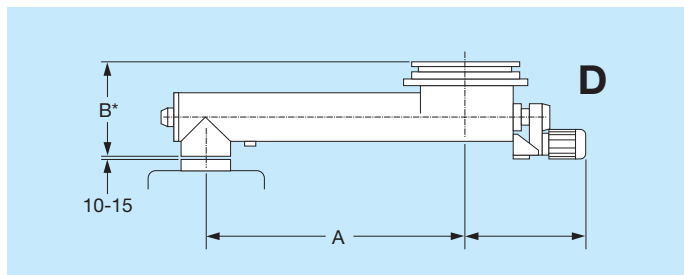

Proportioning and mixing screw DM

Size	160	315	400	500
A mm	1050	1800	1800	1800
B mm	412	597	702	707

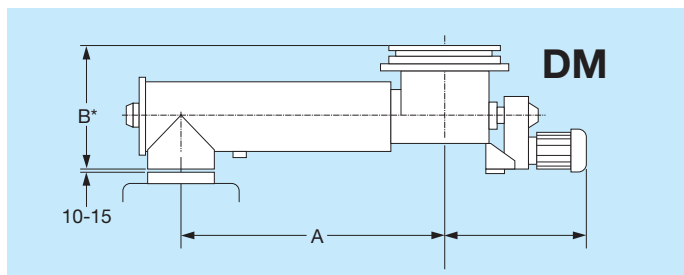

Proportioning and mixing combination KDM

Size	160/ 315	250/ 315	250/ 400
A mm	1800	1800	1800
B mm	902	1026	1131
C mm	780	780	780

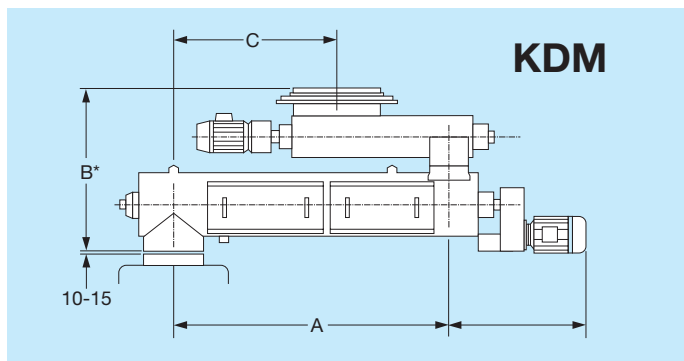

B* = without weld-on collar,
with weld-on collar + 50 mm



AMANDUS KAHL GmbH & Co. KG

Dieselstrasse 5-9
D-21465 Reinbek / Hamburg
Phone: +49 (0)40 727 71 - 0
Fax: +49 (0)40 727 71 - 100

Represented in USA by:
LCI Corporation
PO Box 16348
Charlotte NC 28297
704 394 8341 • fax 704 392 8507
email info@lccorp.com

info@amandus-kahl-group.de
www.akahl.de