

Basket Granulator™

TB-GR-110

The LCI Basket Granulator is the lowest pressure extruder available anywhere. It produces consistent extrudates of wetted powders at high capacities.

The Basket Granulator differs from other low pressure extruders available from LCI because it uses gravity feed rather than screw feed. Aided only by a rotating agitator to prevent arching, wetted powder falls directly into the extrusion area.

The material is wiped through perforated screens by extrusion blades. Extrudates then fall onto a rotating table for discharge.



The LCI Basket Granulator is the lowest pressure extruder available



Features and Benefits

- Adjustable gap between extrusion blade and screen allows optimizing extrusion force
- Low temperature rise due to short-path extrusion
- Choice of extrusion blades to suit process
- Narrow particle size distribution
- High capacity with plug flow operation
- Uniform extrusion pressure across entire screen area
- Screen sizes from 0.5 to 3.0 mm
- Extrudate well suited for spheronization
- Integral safety switches and controls

Applications

The Basket Granulator has proven successful in many areas, including:

- Pharmaceuticals
- Agricultural chemicals
- Soaps/detergents
- Rubber chemicals
- Sugar
- Ceramics
- Heat insulators
- Inorganic chemicals

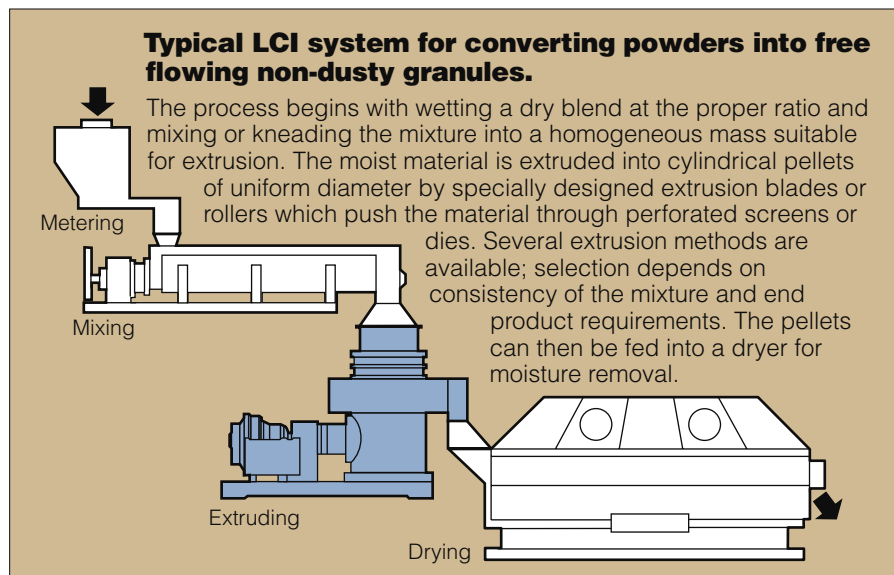

Options

- Explosion proof electricals
- CGMP design
- ACVF variable speed drive
- 316 stainless steel process wetted parts (304 is standard)
- Enlarged discharge table

Specifications overleaf

Basket Granulator Specifications

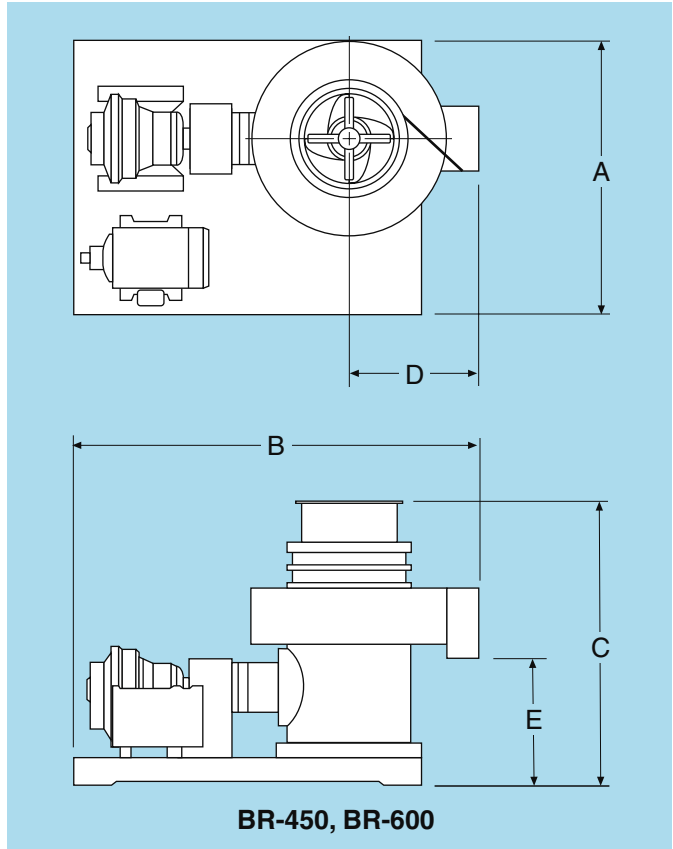
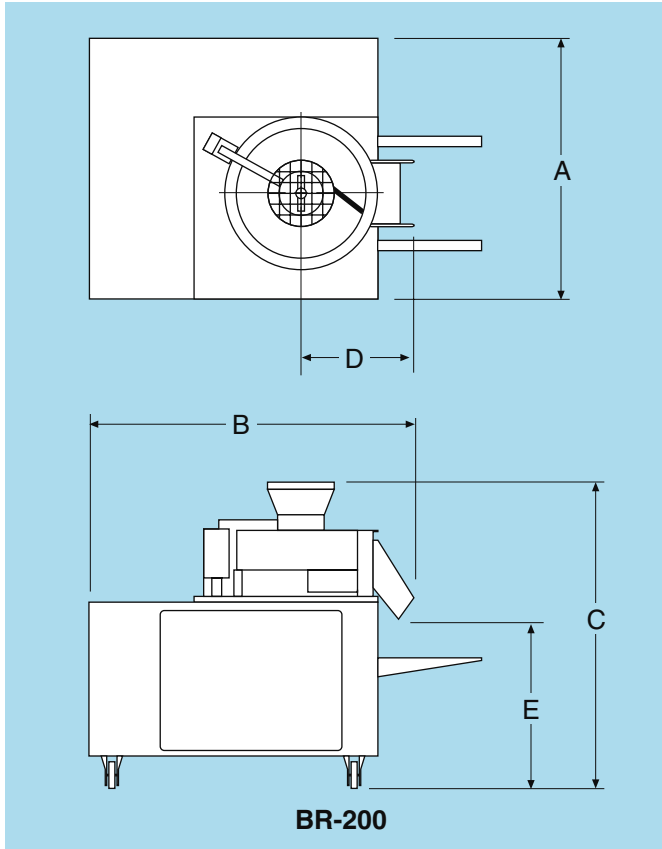

Model	Motor hp	Typical Capacity kg(lb.)/hr	Dimensions					Weight kg(lb.)
			A mm(in.)	B mm(in.)	C mm(in.)	D mm(in.)	E mm(in.)	
BR-200	2	75–250(165–550)	1,000(39)	1,235(49)	1,140(45)	425(17)	630(25)	600(1,300)
BR-450	15	250–1,000(550–2,200)	1,400(55)	2,160(85)	1,365(54)	550(22)	715(28)	1,400(3,100)
BR-600	30	1,000–3,000(2,200–6,600)	2,250(89)	2,295(90)	1,535(60)	820(32)	717(28)	3,000(6,600)

NOTES:

1. Dimensions and weights are approximate and should be used for reference only
2. Capacities are typical maximum rates based on the variety of products processed



LCI Corporation is the exclusive distributor for Fuji Paudal Company, Ltd. in North America.